

**PDH** Academy

## **DC Circuits**

*Mark A. Strain, P.E.*

*PDH301*

*5 Hours*

**Course Material and Final Exam**

# Table of Contents

Introduction.....	2
Ohm's Law.....	2
Voltage.....	3
Current.....	3
Resistance.....	3
$V = IR$ .....	3
Power Dissipation.....	5
Power Rating.....	7
Resistors in Series.....	8
Resistors in Parallel.....	9
Voltage Divider.....	9
Current Divider.....	13
Current Flow and Voltage Polarity.....	15
Series/Parallel Circuits.....	16
Series Circuits.....	16
Parallel Circuits.....	18
Kirchhoff's Circuit Laws.....	21
Kirchhoff's Voltage Law.....	21
Kirchhoff's Current Law.....	25
Circuit Analysis.....	27
Mesh Analysis.....	27
Nodal Analysis.....	31
Summary.....	40
References.....	41

## Introduction

All engineers need a “Back to the Basics!” course and that is exactly what this course provides. The purpose of this course is to utilize the laws associated with basic direct current (DC) theory to find resistances, currents, and voltages at any given point within a circuit. Electric circuits range from very simple circuits containing one or more resistive components and a voltage source (such as a battery and a light bulb contained in a flashlight) to very elaborate, complicated circuits (such as the microprocessor circuit card inside your mobile phone). This course provides a basic introduction to DC resistive circuits and their purpose.

Your mobile phone in your pocket or sitting on the table is a complex circuit containing multiple microprocessors, flash and RAM memories, a display, a cellular radio module as well as WiFi and Bluetooth radio modules, one or more camera modules, a battery, etc. However, complex this circuit is, it can still be simplified to a trivial circuit containing a battery and a resistor.

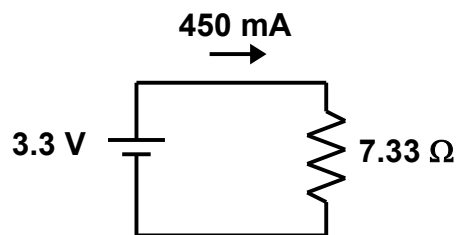

Figure 1 – Simplified equivalent circuit for a mobile phone

Ok, I get it. There are inductive and capacitive effects that need to be considered so the load is not purely resistive. Also, the load is not constant either. The load, or resistance, will fluctuate depending on the current demand on the device (surfing the web, using WiFi or Bluetooth, using GPS, using the camera, display brightness, sound, etc.).

The point is that all circuits can be simplified to fit the model for the parameters that you want to monitor or study. Here we study DC resistive circuits.

## Ohm's Law

All electrical or electronic circuits supplied with a driving voltage from a battery or some sort of power supply will generate a current that passes through the circuit.

As an analogy imagine a river. The water is flowing. The speed at which the river flows depends on the drop in elevation between two points in the river. This drop in elevation is equivalent to voltage. It is a potential difference (whether regarding gravity or voltage) between two points. If you were standing in the river, and the river was small and shallow, you would probably not be knocked over. However, if the river was deep and wide, most likely you would be swept downstream.

The river that swept you downstream most likely contained a lot of moving water, and the river that you were able to stand in had only a little water. The amount of moving water is the current,

just like in an electric circuit. The action of the moving electrons in an electric circuit is the current of the circuit. Resistance comes from obstructions to the free flow of the water in the river, like the river bottom, the river edge, fallen trees, rocks, or humans standing in the middle of the river.

## Voltage

Voltage is measured in volts. One volt is defined as the electrical pressure required to force an electrical current on one amp through a resistance of one ohm.

$$V = \frac{J}{C}$$

(joule / coulomb)

$$= \text{kg m}^2 / \text{A s}^3$$

## Current

Current is measured in amperes (or simply amps). One amp is defined as the current that flows from one coulomb of charge per second.

$$A = \frac{C}{s}$$

(coulomb / second)

## Resistance

Resistance is measured in ohms. One ohm is defined as the electrical resistance between two points of a conductor when a constant potential difference of one volt applied between the two points produces a current of one amp.

## V = IR

The fundamental relationship between voltage, current, and resistance in an electric circuit is known as Ohm's Law. It is represented by the equation  $V = IR$  (where V is the voltage, I is the current, and R is the resistance in the circuit). Ohm's Law states that the current through a conductor between two points is directly proportional to the voltage across the two points. The constant of proportionality is the resistance.

In an electric circuit, we use Ohm's Law to determine the relationship of voltage, current, and resistance. Three equivalent expressions of Ohm's law are used interchangeably:

$$V = IR$$

$$I = \frac{V}{R}$$

$$R = \frac{V}{I}$$

Each equation can be used interchangeably to determine either the voltage drop across a component, current through the component, or resistance of the component.

An ohm is defined as the electrical resistance between two points of a conductor when a constant potential difference of 1 volt, applied to these points, produces in the conductor a current of 1 amp. The units of an ohm ( $\Omega$ ) can be broken down as follows:

$$\begin{aligned}\Omega &= \frac{V}{A} \\ &= \frac{1}{S} \\ &= \frac{W}{A^2} \\ &= \frac{V^2}{W} \\ &= \frac{s}{F} \\ &= \frac{Js}{C^2} \\ &= \frac{kg\ m^2}{sC^2} \\ &= \frac{J}{sA^2} \\ &= \frac{kg\ m^2}{s^3A^2}\end{aligned}$$

in which the following units apply: volt (V), ampere (A), siemens (S), watt (W), second (s), farad (F), joule (J), kilogram (kg), meter (m), coulomb (C).

The definition of  $V / A$  will be sufficient for this course.

The following sample problems will demonstrate how to compute the current through and voltage across a resistive element using Ohm's Law.

**Sample Problem:**

The voltage drop across a 1 k $\Omega$  resistor is 3.3 V. Find the current through the resistor.

Using Ohm's law, we know that  $V = IR$ , or  $I = V / R$ .

$$I = 3.3 / 1000$$
$$I = 0.0033 \text{ V (or 3.3 mV)}$$

### Sample Problem:

The current through a  $49.9\text{k } \Omega$  resistor is  $42.0$  microamps. Find the voltage drop across the resistor.

Once again, using Ohm's law,  $V = IR$ .

$$V = 42 \times 10^{-6} \times 49.9 \times 10^3$$
$$V = 2.10 \text{ V}$$

### Power Dissipation

Part of the process in circuit design is selecting components that are suitable for their intended task. The resistors in a circuit must have the proper power rating to ensure that the component stays within its safe operating limits in terms of current, voltage, and power. Simply put, if there is a current running through a resistor in a circuit, then there is a voltage drop across the resistor and hence power is being dissipated by the component.

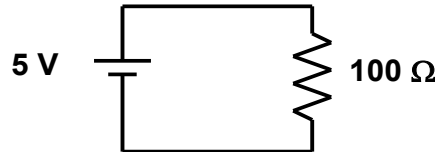

Figure 2 – Simple circuit

The above circuit is one of the simplest circuits possible. The resistor could be a light bulb, a heating element, or just simply a resistor. The battery is hooked up to the resistor with wires or a circuit board to form a complete circuit.

The power dissipated through a resistor is defined by the following equations:

$$P = VI$$
$$= \frac{V^2}{R}$$
$$= I^2R$$

The units are watts or volt-amps (VA). Here is the unit conversion:

$$\begin{aligned} \text{VA} &= \text{J} / \text{C} \times \text{C} / \text{s} \\ &= \text{J} / \text{s} \\ &= \text{kgm}^2 / \text{s}^3 \\ &= \text{W (watt)} \end{aligned}$$

V is the voltage drop across the resistor and I is the current through the resistor. Here the voltage drop is  $V = 5 \text{ V}$ . So, the power is

$$\begin{aligned} P &= \frac{V^2}{R} \\ &= 5^2 / 100 \\ &= 0.25 \text{ watts (W)} \end{aligned}$$

**Sample Problem:**

The voltage across a  $1 \text{ k}\Omega$  resistor is  $3.3 \text{ V}$ . Find the power dissipated by the resistor.

Using the power dissipation equation

$$P = \frac{V^2}{R}$$

we find that

$$\begin{aligned} P &= 3.3^2 / 1000 \\ P &= 0.0109 \text{ W} \\ &= 10.9 \text{ mW} \end{aligned}$$

**Sample Problem:**

The current running through a  $10 \text{ k}\Omega$  resistor is  $5 \text{ mA}$ . Find the power dissipated by the resistor.

Using the power dissipation equation

$$\begin{aligned} P &= I^2 R \\ P &= 0.005^2 \times 10000 \\ P &= 0.25 \text{ W} \end{aligned}$$

## Power Rating

Electrical power is the rate at which energy is used or dissipated as heat. The power rating of a resistor is a number given by the manufacturer, given in watts. It is the maximum amount of power that the resistor can safely dissipate without overheating or damaging the part. Its value is based mainly on the resistor's size. The power rating can be qualified by the amount of heat that a resistive element can dissipate for an indefinite period of time without degrading its performance.

A resistor can be used with various combinations of voltage and current just as long as its power rating is not exceeded. So, the circuit designer must select a component that has a power rating greater than its the maximum power to be dissipated by the component at any given time. Power ratings can vary from less than a tenth of a watt to hundreds of watts or more depending on its size, design and composition (carbon, thin film, wire wound), and the ambient temperature.

### Sample Problem:

Calculate the maximum safe current through a  $100\ \Omega$  resistor with a power rating of  $0.5\ \text{W}$ .

Using the power dissipation equation

$$P = I^2R$$

$$I = \sqrt{\frac{P}{R}}$$

$$I = \sqrt{\frac{0.5}{100}}$$

$$I = 0.0707\ \text{A}$$

$$= 70.7\ \text{mA}$$

So, the resistor can pass a maximum current of  $70.7\ \text{mA}$ .

### Sample Problem:

A  $4.7\ \text{k}\Omega$  resistor is part of a circuit and has a maximum current of  $8\ \text{mA}$  passing through it. What is the maximum power rating of the resistor, and what resistor should be selected if the available components have power ratings of  $0.25\ \text{W}$ ,  $0.5\ \text{W}$ , and  $0.75\ \text{W}$ ?

Using the power dissipation equation, the maximum power rating of the resistor is

$$P = I^2R$$

$$P = 0.008^2 \times 4700$$

$$= 0.301\ \text{W}$$



Therefore, 0.5 W is an appropriate power rating for the resistor in this circuit. A 0.75 W resistor would also work fine, but is perhaps larger than necessary for the circuit. The 0.25 W resistor's power rating is insufficient for this circuit and would most likely overheat.

## Resistors in Series

The total resistance in a series circuit is equal to the sum of the individual resistances and can be found using the following equation:

$$R_T = R_1 + R_2 + R_3 + \dots$$

where  $R_T$  is the total resistance and  $R_1$ ,  $R_2$ , and  $R_3$  are the individual resistors in series.

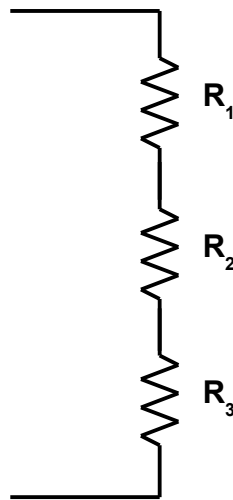

Figure 3 – Resistors in series

### Sample Problem:

A series circuit has a 100  $\Omega$ , a 200  $\Omega$ , and a 250  $\Omega$  resistor in series. What is the total resistance of the circuit?

$$\begin{aligned} R_T &= R_1 + R_2 + R_3 \\ &= 100 + 200 + 250 \\ &= 550 \Omega \end{aligned}$$

## Resistors in Parallel

The total resistance in a parallel circuit can be found using the equation below. The “||” symbol denotes two elements in parallel.

$$R_T = R_1 \parallel R_2 \parallel R_3$$

$$\frac{1}{R_T} = \frac{1}{R_1} + \frac{1}{R_2} + \frac{1}{R_3} + \dots$$

where  $R_T$  is the total resistance and  $R_1$ ,  $R_2$ , and  $R_3$  are the individual resistors in parallel.

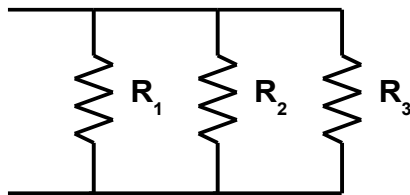

Figure 4 – Resistors in parallel

### Sample Problem:

A parallel circuit has a 150  $\Omega$ , a 200  $\Omega$ , and a 250  $\Omega$  resistor in parallel. What is the total resistance of the circuit?

$$\begin{aligned} \frac{1}{R_T} &= \frac{1}{R_1} + \frac{1}{R_2} + \frac{1}{R_3} + \dots \\ &= 1 / 150 + 1 / 200 + 1 / 250 \\ &= 0.0157 \\ R_T &= 63.8 \Omega \end{aligned}$$

## Voltage Divider

A voltage divider is a simple circuit which turns a large voltage into a smaller one. It is a network of two or more resistors in series that is used to obtain a different voltage value from a voltage source. The resulting voltage value is always lower in magnitude than the voltage source.

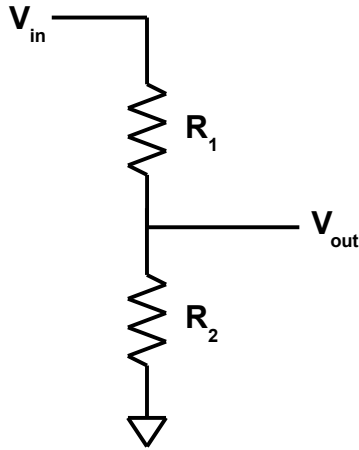

Figure 5 – Simple voltage divider

In this circuit, the input voltage is applied to two resistors in series. The output voltage is taken between the two resistors. The output is obtained using the following equation:

$$V_{out} = V_{in} \frac{R_2}{R_1 + R_2}$$

**Sample Problem:**

Find the output voltage of a voltage divider with  $R_1 = 10 \text{ k}\Omega$ ,  $R_2 = 15 \text{ k}\Omega$ , and an input voltage of 12 V.

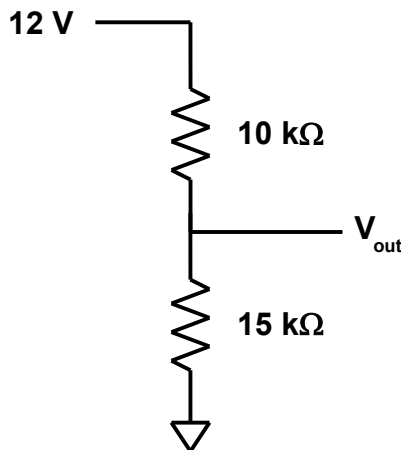

Figure 6 – Voltage divider sample problem

The output voltage is found using the voltage divider equation:

$$V_{out} = V_{in} \frac{R_2}{R_1 + R_2}$$

$$\begin{aligned} V_{out} &= 12(15000) / (10000 + 15000) \\ &= 7.2 \text{ V} \end{aligned}$$

Voltage dividers may have multiple outputs if additional resistors are connected in series:

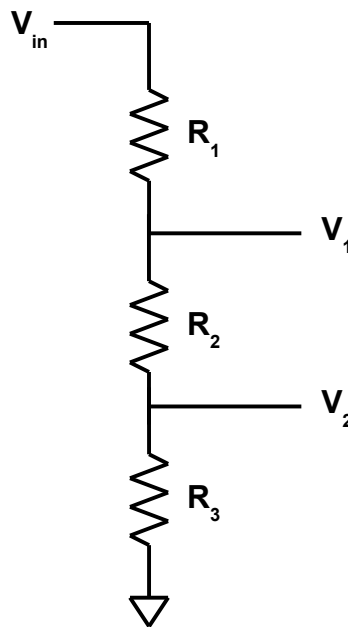

Figure 7 – Voltage divider with multiple output voltages

In this circuit, the input voltage is applied to resistor series network. The output voltage is obtained using the following equations:

$$V_1 = V_{in} \frac{R_2 + R_3}{R_1 + R_2 + R_3}$$

$$V_2 = V_{in} \frac{R_3}{R_1 + R_2 + R_3}$$

**Sample Problem:**

Find the two output voltages of a voltage divider with  $R_1 = 100 \Omega$ ,  $R_2 = 150 \Omega$ ,  $R_3 = 200 \Omega$ , and an input voltage of 12 V.

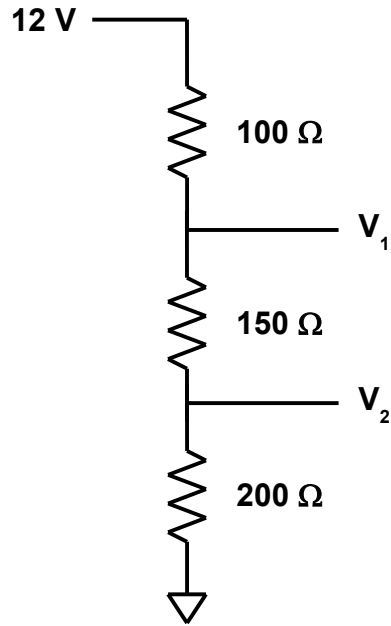

**Figure 8 – Voltage divider sample problem**

The output voltage,  $V_1$ , is found using the following equation:

$$V_1 = V_{in} \frac{R_2 + R_3}{R_1 + R_2 + R_3}$$

$$V_1 = 12(150 + 200) / (100 + 150 + 200) \\ = 9.33 \text{ V}$$

and the output voltage,  $V_2$ , is found using the following equation:

$$V_2 = V_{in} \frac{R_3}{R_1 + R_2 + R_3}$$

$$V_2 = 12(200) / (100 + 150 + 200) \\ = 5.33 \text{ V}$$

## Current Divider

A current divider is a simple circuit that produces an output current that is a fraction of its input current. It is a network of two or more resistors in parallel that is used to divide the total current in a branch into fractional currents in each branch. The resulting current in the individual branches is always smaller than the current in the main branch.

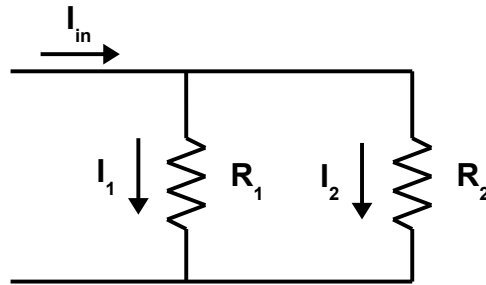

Figure 9 – Simple current divider

In this circuit, a current,  $I_{in}$ , is applied to the network of two resistors. The resulting current in each of the two branches,  $I_1$  and  $I_2$ , can be found using the following equations:

$$I_1 = I_{in} \frac{R_2}{R_1 + R_2}$$

$$I_2 = I_{in} \frac{R_1}{R_1 + R_2}$$

$$I_{in} = I_1 + I_2$$

### Sample Problem:

Find the individual branch currents,  $I_1$  and  $I_2$ , given the current divider below with  $R_1 = 1 \text{ k}\Omega$  and  $R_2 = 4.7 \text{ k}\Omega$ .

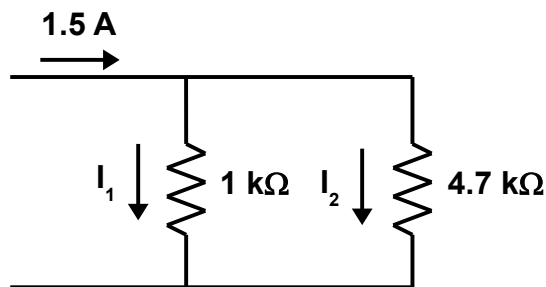

Figure 10 – Current divider sample problem

The branch current,  $I_1$ , is found using the following equation:

$$I_1 = I_{in} \frac{R_2}{R_1 + R_2}$$

$$\begin{aligned} I_1 &= 1.5(4700) / (1000 + 4700) \\ &= 1.24 \text{ A} \end{aligned}$$

and the branch current,  $I_2$ , is found using the following equation:

$$I_2 = I_{in} \frac{R_1}{R_1 + R_2}$$

$$\begin{aligned} I_2 &= 1.5(1000) / (1000 + 4700) \\ &= 0.263 \text{ A} \end{aligned}$$

Notice that the following equation holds true:

$$I_{in} = I_1 + I_2$$

$$\begin{aligned} I_{in} &= 1.24 + 0.263 \\ &= 1.50 \text{ A} \end{aligned}$$

Current dividers may have more than two resistors, just as voltage dividers may have more than two resistive elements. In order to compute the individual current in each branch, compute the voltage drop across each resistor. The voltage drop is the same across each resistor. It is computed using Ohm's Law using the total current and the equivalent resistance of the circuit. The total current is the sum of all of the individual branch currents.

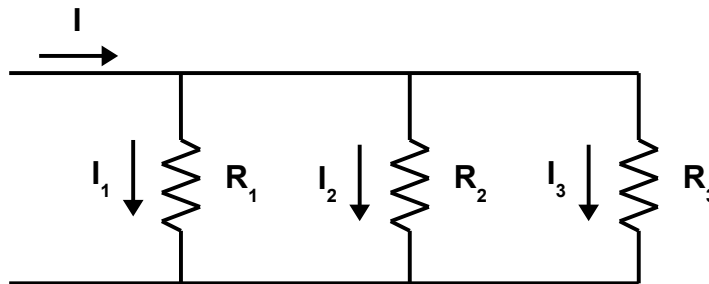

Figure 11 – Current divider with more than two resistors

The equivalent resistance is given by

$$R_T = R_1 \parallel R_2 \parallel R_3$$

$$\frac{1}{R_T} = \frac{1}{R_1} + \frac{1}{R_2} + \frac{1}{R_3} + \dots$$

The voltage drop is given by

$$V = IR_T$$

Now, each of the individual currents may be computed using Ohm's Law

$$I = \frac{V}{R}$$

$$I_1 = \frac{V}{R_1}$$

$$I_2 = \frac{V}{R_2}$$

$$I_3 = \frac{V}{R_3}$$

## Current Flow and Voltage Polarity

In an electric circuit, current flow is defined as the flow of electric charge. In a circuit this charge is carried by the flow of electrons. Current in a wire or conductor can flow in either direction. Positive charges flow toward negative charges, and negative charges flow toward positive charges.

The direction of conventional current flow is arbitrarily defined as the same direction as positive charges flow. Electrons flow in the opposite direction of conventional current flow in an electrical circuit. If the calculated current in a circuit or circuit loop turns out to be negative, then the flow is in the opposite direction of that which was chosen. The direction is arbitrary. It is important to be consistent, though. Conventional current flow is almost always used in circuit analysis.

Conventional current flows through a source from the negative to the positive. Voltage is added when flowing through a source. Sometimes the "+" symbol is noted on the voltage source, but other times it is not. The positive charge is always on the side of the longest line. The shortest line is the negative charge.

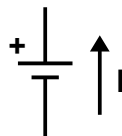



Figure 12 – Conventional current flowing through a source

When conventional current flows through a resistor, the voltage drop across the resistor is subtracted.

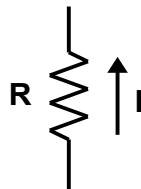

Figure 13 – Conventional current flowing through a resistor

## Series/Parallel Circuits

Circuit components can be connected in two basic ways: series and parallel or using a combination of both series and parallel branches.

### Series Circuits

A series circuit has only one path for current flow. The current in a series circuit will be the same throughout the circuit. In a series circuit with three resistors in series ( $R_1$ ,  $R_2$ , and  $R_3$ ), the current flow through  $R_1$  is the same as the current flow through  $R_2$  and  $R_3$ .

The total voltage drop in a series circuit is equivalent to the sum of the individual voltage drops across each resistor. The voltage drop can be calculated using Ohm's Law:  $V = IR$ .

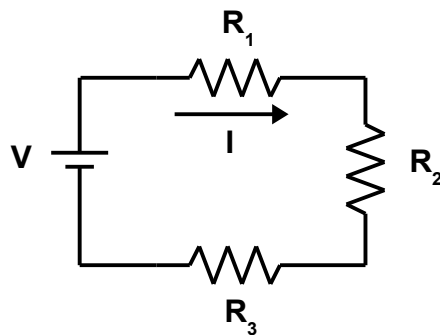

Figure 14 – Series circuit

The total voltage across a series circuit is the sum of the individual voltages across each resistor

$$V = V_1 + V_2 + V_3 + \dots$$

where  $V$  is the total voltage drop across all three resistors

$V_1$  is the voltage drop across  $R_1$

and  $V_2$  is the voltage drop across  $R_2$

and  $V_3$  is the voltage drop across  $R_3$

The current in a series circuit is the same through each component. Ohm's law may be used to find the current in the circuit or to find the individual voltage drop across each resistor (given either the total voltage in the circuit or the current).

### Sample Problem:

A series circuit has a  $150\ \Omega$ , a  $200\ \Omega$ , and a  $50\ \Omega$  resistor in series. If the total voltage in the circuit is  $12\ \text{V}$ , find the current in the circuit. Find the individual voltage drop for each resistor.

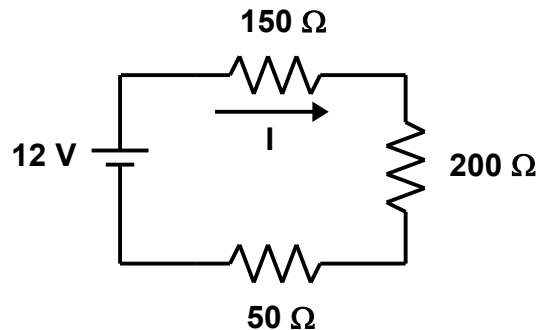

Figure 15 – Series circuit sample problem

The total resistance in the circuit is the sum of all of the resistances since they are connected in series.

$$\begin{aligned}R_T &= R_1 + R_2 + R_3 \\ &= 150 + 200 + 50 \\ &= 400\ \Omega\end{aligned}$$

The total current can be found using Ohm's Law:

$$\begin{aligned}V &= IR, \text{ or} \\ I &= V / R \\ &= 12 / 400 \\ &= 0.03\ \text{A}\end{aligned}$$

The individual voltage drops across each resistor can also be found using Ohm's Law. The current is the total current in the circuit that was just computed above.

$$V = IR$$

$$\begin{aligned} V_1 &= IR_1 = 0.03(150) \\ &= 4.5 \text{ V} \end{aligned}$$

$$\begin{aligned} V_2 &= IR_2 = 0.03(200) \\ &= 6 \text{ V} \end{aligned}$$

$$\begin{aligned} V_3 &= IR_3 = 0.03(50) \\ &= 1.5 \text{ V} \end{aligned}$$

Notice that the individual voltages sum to the total voltage in the circuit:

$$4.5 + 6 + 1.5 = 12 \text{ V}$$

## Parallel Circuits

A parallel circuit has many paths for current to follow.

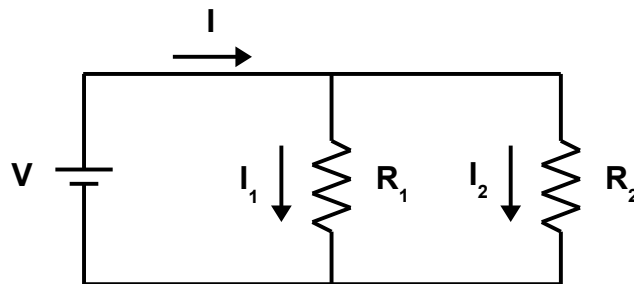

Figure 16 – Parallel circuit

The total current is equal to the sum of the individual paths of current.

$$I = I_1 + I_2$$

The voltage drop across the two resistors is the same since they are in parallel with one another. The current in the individual branches may be found using Ohm's Law:

$$I_1 = \frac{V}{R_1}$$

$$I_2 = \frac{V}{R_2}$$

In a parallel circuit with three resistors ( $R_1$ ,  $R_2$ , and  $R_3$ ), the voltage drop across each resistor is the same.

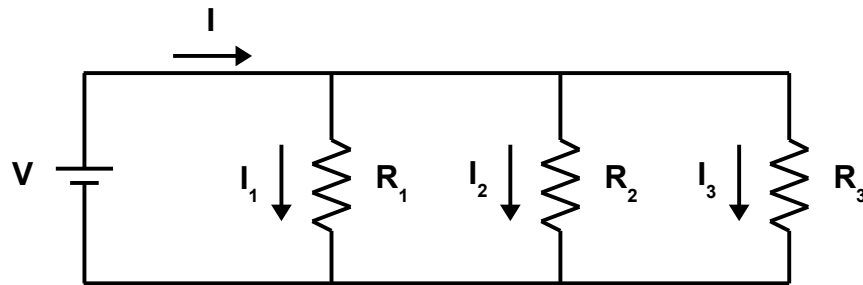

Figure 17 – Parallel circuit

The total current is equal to the sum of the individual paths of current.

$$I = I_1 + I_2 + I_3$$

As in the two-resistor example, the voltage drop across each resistor is the same, since all three resistors are in parallel. The current through each resistor can be calculated using Ohm's Law:

$$I_1 = \frac{V}{R_1}$$

$$I_2 = \frac{V}{R_2}$$

$$I_3 = \frac{V}{R_3}$$

Where  $V$  is the source voltage,  $I$  is the current in the branch ( $I_1$ , for example) and  $R$  is resistance of the branch ( $R_1$ , for example).

### Sample Problem:

A parallel circuit has three resistors in parallel ( $100 \Omega$ ,  $150 \Omega$ , and  $300 \Omega$ ) with a source voltage of  $24 \text{ V}$ . Find the individual currents and the total current in the circuit.

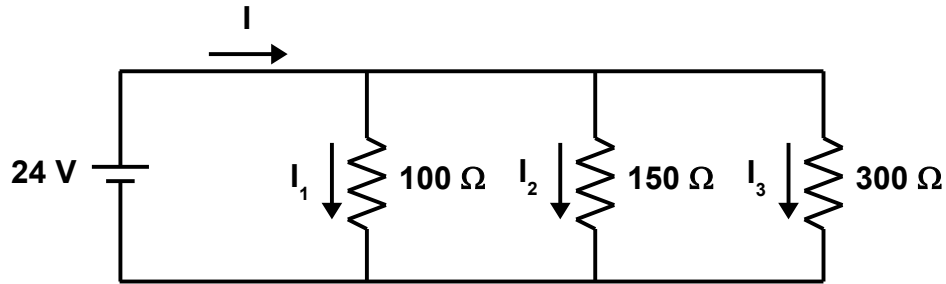

Figure 18 – Parallel circuit sample problem

The voltage drop across all of the resistors is equivalent to the source voltage (24 V) since the resistors are in parallel to the source voltage.

The individual currents are given by the following equations:

$$I_1 = \frac{V}{R_1}$$

$$I_2 = \frac{V}{R_2}$$

$$I_3 = \frac{V}{R_3}$$

Therefore,

$$I_1 = \frac{V}{R_1}$$

$$= 24 / 100$$

$$= 0.24 \text{ A}$$

$$I_2 = \frac{V}{R_2}$$

$$= 24 / 150$$

$$= 0.16 \text{ A}$$

$$I_3 = \frac{V}{R_3}$$

$$= 24 / 300$$

$$= 0.08 \text{ A}$$

The total current is given by the following equation:

$$\begin{aligned} I &= I_1 + I_2 + I_3 \\ &= 0.24 + 0.16 + 0.08 \\ &= 0.48 \text{ A} \end{aligned}$$

## Kirchhoff's Circuit Laws

Kirchhoff's circuit laws (Kirchhoff's Voltage Law and Kirchhoff's Current Law) are two laws that deal with voltage and current in lumped element model of electrical circuits. They are named after the German physicist Gustav Kirchhoff in 1857. Kirchhoff developed methods to solve complex circuits. He developed two laws, known today as Kirchhoff's Laws.

Law 1: The current arriving at the junction point in a circuit is equal to the current leaving that junction (Kirchhoff's Current Law).

Law 2: The sum of the voltage drops around a closed loop is equal to the sum of the voltage sources of that loop (Kirchhoff's Voltage Law).

Kirchhoff's laws are related to the conservation of energy and conservation of charge. Since all of the power provided by the source in a circuit is consumed by the load, energy and charge are conserved.

## Kirchhoff's Voltage Law

Kirchhoff's Voltage Law (KVL) is a law used in circuit analysis that deals with the conservation of energy around a closed circuit path. This law is also known as the loop rule or mesh rule or Kirchhoff's second rule.

The principle of conservation of energy implies that the sum of the voltage drops around any closed network is zero. Or, the sum of the emfs (electromotive force) in any closed loop is equivalent to the sum of the potential drops in that loop. The algebraic sum of all of the voltages in a closed loop is equal to zero. The term algebraic sum means to take into account the polarities of the sources and the voltage drops around the loop.

$$\Sigma V = 0$$

or

$$\Sigma E_{\text{source}} = \Sigma IR$$

(The sum of all of the sources within a loop is equal to the sum of the voltage drops in the loop).

The idea is that as you move around a closed loop in a circuit you will end up where you started in the circuit and therefore back to the initial potential with no loss of potential around the loop. So, the voltage drops around the loop must equal all of the sources within the loop.

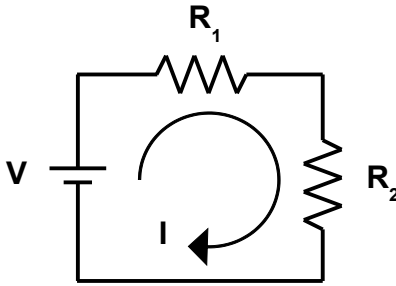

**Figure 19 – Parallel circuit sample problem**

The two resistors and the source are in series, so they are part of the same circuit loop. The same current must flow through each resistor. Thus, the voltage drop across resistor  $V_1 = IR_1$ , and the voltage drop across resistor  $V_2 = IR_2$ . The voltage of the source is  $V_s$ . Kirchhoff's Voltage Law states that:

$$V_s - IR_1 - IR_2 = 0$$

$$V_s = IR_1 + IR_2$$

$$V_s = I(R_1 + R_2)$$

so, the current is given by

$$I = V_s / (R_1 + R_2)$$

or using the total (or equivalent) resistance in the circuit

$$R_T = R_1 + R_2$$

$$I = V_s / R_T$$

and the voltage drop across each resistor is given by

$$V_{R1} = IR_1$$

$$V_{R2} = IR_2$$

**Sample Problem:**

Find the current and the voltage drop across each resistor in a circuit with three resistors (4.7 k $\Omega$ , 1.5 k $\Omega$ , 2.3 k $\Omega$ ) in series across a voltage source of 12 V.

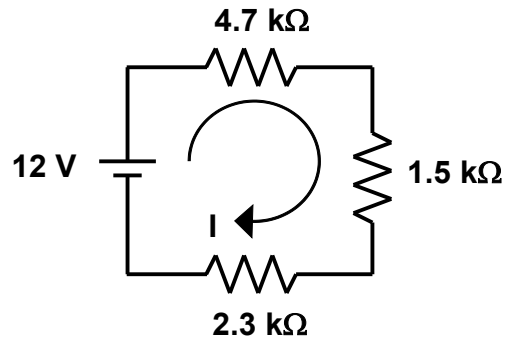

Figure 20 – Kirchoff's Voltage Law sample problem

The current is the same through each resistor. The current is found by summing the voltage drops in the loop.

$$\begin{aligned}
 V_s - IR_1 - IR_2 - IR_3 &= 0 \\
 12 - 4700I - 1500I - 2300I &= 0 \\
 (4700 + 1500 + 2300)I &= 12 \\
 8500I &= 12 \\
 I &= 0.00141 \text{ A} \\
 &= 1.41 \text{ mA}
 \end{aligned}$$

The voltage drops are found by

$$\begin{aligned}
 V_1 &= IR_1 \\
 &= 0.00141(4700) \\
 &= 6.64 \text{ V}
 \end{aligned}$$

$$\begin{aligned}
 V_2 &= IR_2 \\
 &= 0.00141(1500) \\
 &= 2.12 \text{ V}
 \end{aligned}$$

$$\begin{aligned}
 V_3 &= IR_3 \\
 &= 0.00141(2300) \\
 &= 3.25 \text{ V}
 \end{aligned}$$

The individual voltage drops should equal the voltage source.

$$6.64 + 2.12 + 3.25 + 12.0 \text{ V}$$



**Sample Problem:**

Find the current and the voltage drop across each resistor in a circuit with two resistors (250  $\Omega$  and 300  $\Omega$ ) and two voltage sources (12 V and 24 V).

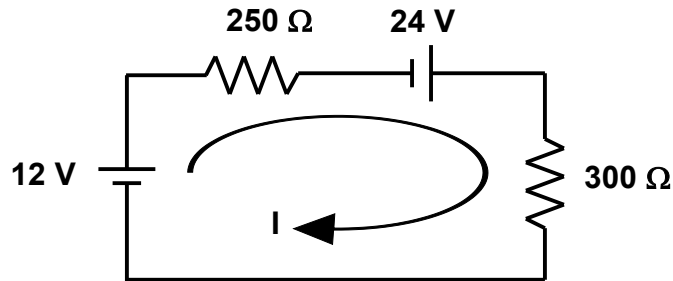

**Figure 21 – Kirchhoff's Voltage Law sample problem**

The current is the same through each resistor. While completing the loop, the voltages are added in the direction that the arrow is pointed. The voltage drops are always subtracted.

$$V_{s1} - IR_1 + V_{s2} - IR_2 = 0$$

$$12 - 250I + 24 - 300I = 0$$

$$36 - 550I = 0$$

$$550I = 36$$

$$I = 0.0655 \text{ A}$$

$$I = 65.5 \text{ mA}$$

$$\begin{aligned} V_1 &= IR_1 \\ &= 0.0655(250) \\ V_1 &= 16.4 \text{ V} \end{aligned}$$

$$\begin{aligned} V_2 &= IR_2 \\ &= 0.0655(300) \\ V_2 &= 19.6 \text{ V} \end{aligned}$$

All of the source voltages and the voltages must add up to zero.

$$V_{s1} + V_{s2} - V_1 - V_2 = 0$$

$$12 + 24 - 16.4 - 19.6 = 0$$

$$36 - 36 = 0$$

### Kirchhoff's Current Law

Kirchhoff's Current Law utilizes the principle of conservation of charge. A node or junction in a circuit is a point where three or more branches come together. At any node in a circuit the sum of currents flowing into the node is equal to the sum of the currents flowing out of the node. All current flowing into a node must also flow out. No charge may build up. Just as water flows through a pipe, all water flowing into a junction must also flow out of the junction.

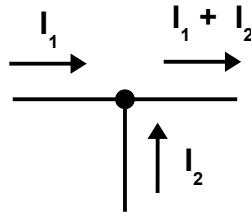

Figure 22 – Kirchhoff's Current Law

The current flowing out of the junction is equal to the sum of the currents flowing into the junction:  $I_1 + I_2$ .

### Sample Problem:

Find the currents in the circuit below.

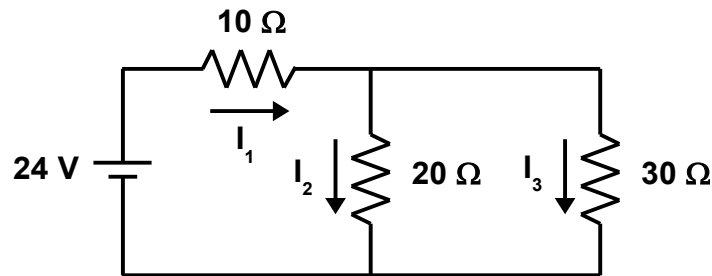

Figure 23 – Kirchhoff's Current Law sample problem

First, apply Kirchhoff's voltage law in both loops.

$$24 - 10I_1 - 20I_2 = 0$$

$$-30I_3 + 20I_2 = 0$$

Next, apply Kirchhoff's current law at the node.

$$I_1 = I_2 + I_3$$

$$I_3 = I_1 - I_2$$

So, there are three equations and three unknowns.

$$24 - 10I_1 - 20I_2 = 0$$

$$10I_1 + 20I_2 = 24$$

$$-30I_3 + 20I_2 = 0$$

$$20I_2 = 30I_3$$

$$20I_2 = 30(I_1 - I_2)$$

$$20I_2 = 30I_1 - 30I_2$$

$$50I_2 = 30I_1$$

$$I_2 = (30/50)I_1 = 3/5I_1$$

$$10I_1 + 20I_2 = 24$$

$$10I_1 + 20(3/5)I_1 = 24$$

$$10I_1 + 12I_1 = 24$$

$$22I_1 = 24$$

$$I_1 = 1.091 \text{ A}$$

$$I_2 = 3/5I_1$$

$$= (3/5)(1.091)$$

$$I_2 = 0.655 \text{ A}$$

$$I_3 = I_1 - I_2$$

$$= 1.091 - 0.655$$

$$I_3 = 0.436 \text{ A}$$

# Circuit Analysis

## Mesh Analysis

Mesh analysis is a form of circuit analysis that determines the individual loop currents. A loop current is a current path in a portion of a circuit that can be traced from any given point and followed around a circuit loop and ending up back at the same point. This form of analysis produces loop equations.

### Sample Problem:

Solve for  $I_1$  and  $I_2$  in the circuit below using mesh analysis.

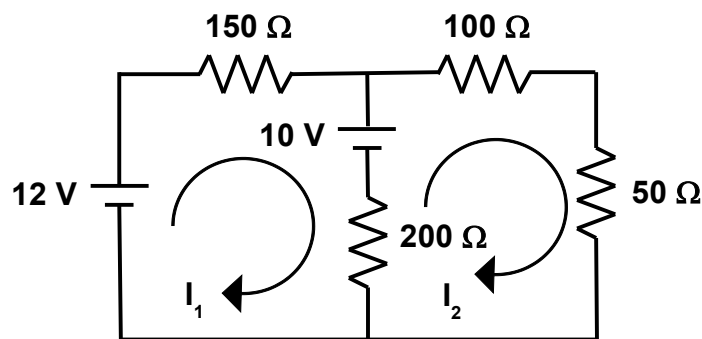

Figure 24 – Mesh analysis sample problem

The direction of current in the two loops is assumed to be in the direction drawn. If the assumed direction is incorrect, it does not matter, the current will simply be negative. The current in the  $200\ \Omega$  resistor is either  $I_1 - I_2$  or  $I_2 - I_1$  depending on which loop is being evaluated.

First, analyze loop 1:

$$12 - 150I_1 - 10 - 200(I_1 - I_2) = 0$$

Next, analyze loop 2:

$$-100I_2 - 50I_2 - 200(I_2 - I_1) + 10 = 0$$

Finally solve for  $I_1$  and  $I_2$ :

$$12 - 10 - 150I_1 - 200I_1 + 200I_2 = 0$$

$$350I_1 - 200I_2 = 2$$

$$350I_1 = 2 + 200I_2$$

$$I_1 = (2 + 200I_2) / 350$$

$$\begin{aligned}
 -100I_2 - 50I_2 - 200I_2 + 200I_1 + 10 &= 0 \\
 -200I_1 + 350I_2 &= 10 \\
 -200(2 + 200I_2) / 350 &= 350I_2 = 10 \\
 -200(2 + 200I_2) + 350(350)I_2 &= 3500 \\
 -400 - 40000I_2 + 350(350)I_2 &= 3500 \\
 82500I_2 &= 3900 \\
 I_2 &= 0.0473 \text{ A} \\
 &= 47.3 \text{ mA}
 \end{aligned}$$

$$\begin{aligned}
 I_1 &= (2 + 200(0.0473)) / 350 \\
 I_1 &= 0.0327 \text{ A} \\
 &= 32.7 \text{ mA}
 \end{aligned}$$

**Sample Problem:**

Solve for  $I_1$ ,  $I_2$ , and  $I_3$  in the circuit below using mesh analysis.

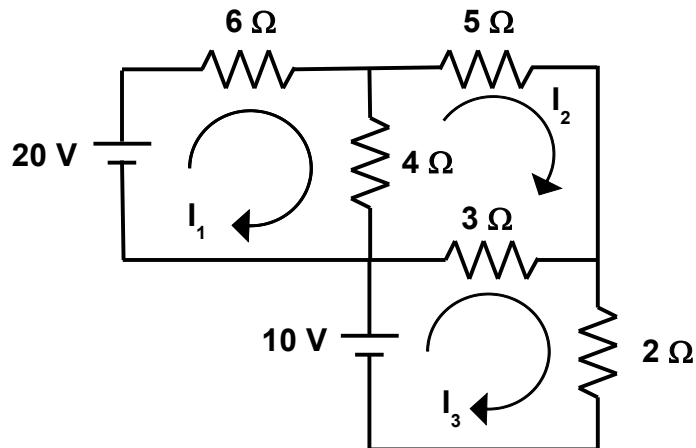

Figure 25 – Mesh analysis sample problem

As in the previous example, the direction of current in the three loops is assumed to be in the direction drawn. The current in the  $4 \Omega$  resistor is  $I_1 - I_2$  in loop #1, and the current is  $I_2 - I_1$  in loop #2. The current in the  $3 \Omega$  resistor is  $I_2 - I_3$  in loop #2, and the current is  $I_3 - I_2$  in loop #3. These current directions that are chosen are arbitrary, but must remain consistent throughout the analysis.

First, analyze loop 1:

$$20 - 6I_1 - 4(I_1 - I_2) = 0$$

Next, analyze loop 2:

$$-4(I_2 - I_1) - 5I_2 - 3(I_2 - I_3) = 0$$

Next, analyze loop 3:

$$10 - 3(I_3 - I_2) - 2I_3 = 0$$

Finally, solve for  $I_1$ ,  $I_2$ , and  $I_3$ :

$$20 - 6I_1 - 4(I_1 - I_2) = 0$$

$$20 - 6I_1 - 4I_1 + 4I_2 = 0$$

$$10I_1 - 4I_2 = 20$$

$$10I_1 = 20 + 4I_2$$

$$I_1 = 2 + 0.4I_2$$

$$-4(I_2 - I_1) - 5I_2 - 3(I_2 - I_3) = 0$$

$$-4I_2 + 4I_1 - 5I_2 - 3I_2 + 3I_3 = 0$$

$$4I_1 - 12I_2 + 3I_3 = 0$$

$$12I_2 = 4I_1 + 3I_3$$

$$I_2 = 0.333I_1 + 0.25I_3$$

$$I_2 = 0.333(2 + 0.4I_2) + 0.25I_3$$

$$I_2 = 0.666 + 0.133I_2 + 0.25I_3$$

$$0.867I_2 = 0.666 + 0.25I_3$$

$$I_2 = 0.768 + 0.288I_3$$

$$10 - 3(I_3 - I_2) - 2I_3 = 0$$

$$10 - 3I_3 + 3I_2 - 2I_3 = 0$$

$$10 - 5I_3 + 3I_2 = 0$$

$$5I_3 = 10 + 3I_2$$

$$5I_3 = 10 + 3(0.333I_1 + 0.25I_3)$$

$$5I_3 = 10 + I_1 + 0.75I_3$$

$$4.25I_3 = 10 + I_1$$

$$4.25I_3 = 10 + 2 + 0.4I_2$$

$$4.25I_3 = 10 + 2 + 0.4(0.768 + 0.288I_3)$$

$$4.25I_3 = 10 + 2 + 0.307 + 0.115I_3$$

$$4.13I_3 = 12.3$$

$$I_3 = 2.98 \text{ A}$$

$$I_2 = 0.768 + 0.288I_3$$

$$= 0.768 + 0.288(2.98)$$

$$I_2 = 1.63 \text{ A}$$

$$I_1 = 2 + 0.4I_2$$

$$= 2 + 0.4(1.63)$$

$$I_1 = 2.65 \text{ A}$$

Finally, the three loop currents are

$$I_1 = 2.65 \text{ A}$$

$$I_2 = 1.63 \text{ A}$$

$$I_3 = 2.98 \text{ A}$$

To check, put the three currents back into the original loop current equations:

$$20 - 6I_1 - 4(I_1 - I_2) = 0$$

$$20 - 6(2.65) - 4(2.65 - 1.63) =$$

$$20 - 15.9 - 4.08 = 0.02 \text{ (approx. 0)}$$

$$-4(I_2 - I_1) - 5I_2 - 3(I_2 - I_3) = 0$$

$$-4(1.63 - 2.65) - 5(1.63) - 3(1.63 - 2.98) =$$

$$4.08 - 8.15 + 4.05 = -0.02 \text{ (approx. 0)}$$

$$10 - 3(I_3 - I_2) - 2I_3 = 0$$

$$10 - 3(2.98 - 1.64) - 2(2.98) =$$

$$10 - 4.02 - 5.96 = 0.02 \text{ (approx. 0)}$$

## Nodal Analysis

Nodal Analysis or branch current method produces node equations.

### Sample Problem:

Solve for  $I_1$ ,  $I_2$ , and  $I_3$  in the circuit below using nodal analysis.

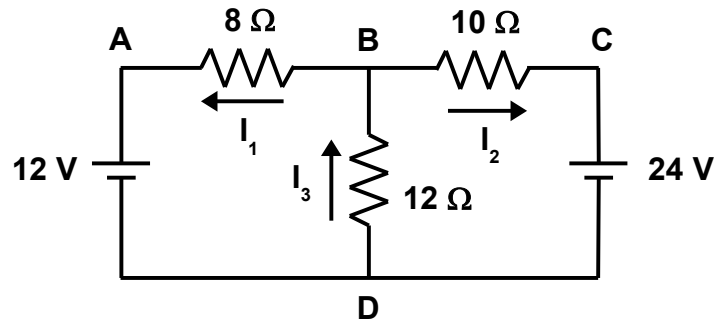

Figure 26 – Nodal analysis sample problem

At node B there are two currents leaving and one current arriving. The node equation at B is thus:

$$-I_1 - I_2 + I_3 = 0$$

$$I_3 = I_1 + I_2$$

According to Ohm's Law, the voltage drop across a resistor is equal to the current through the resistor times its resistance. So, now compute the voltage drops across all of the resistors. The polarity will be considered positive in the direction of the conventional current flow. Three equations are written for the three resistors:

$$V_A - V_B = 8I_1$$

$$V_C - V_B = 10I_2$$

$$V_B - V_D = 12I_3$$

Substitute the known voltages into the equations:

$$V_A = 12 \text{ V}$$

$$V_C = 24 \text{ V}$$



$$V_D = 0$$

$$V_A - V_B = 8I_1$$

$$12 - V_B = 8I_1$$

$$V_C - V_B = 10I_2$$

$$24 - V_B = 10I_2$$

$$V_B - V_D = 12I_3$$

$$V_B - 0 = 12I_3$$

$$V_B = 12I_3$$

We have 4 equations and 4 unknowns:

$$I_3 = I_1 + I_2$$

$$12 - V_B = 8I_1$$

$$24 - V_B = 10I_2$$

$$V_B = 12I_3$$

$$12 - V_B = 8I_1$$

$$12 - 12I_3 = 8I_1$$

$$24 - V_B = 10I_2$$

$$24 - 12I_3 = 10I_2$$

Substitute  $I_3 = I_1 + I_2$

$$12 - 12(I_1 + I_2) = 8I_1$$

$$12 - 12I_1 - 12I_2 = 8I_1$$

$$20I_1 = 12 - 12I_2$$

$$I_1 = 0.6 - 0.6I_2$$

$$24 - 12I_3 = 10I_2$$

$$24 - 12(I_1 + I_2) = 10I_2$$

$$24 - 12I_1 - 12I_2 = 10I_2$$

$$22I_2 = 24 - 12I_1$$

Substitute in for  $I_1$ :

$$22I_2 = 24 - 12(0.6 - 0.6I_2)$$

$$22I_2 = 24 - 7.2 + 7.2I_2$$

$$14.8I_2 = 16.8$$

$$I_2 = 1.14 \text{ A}$$

$$I_1 = 0.6 - 0.6I_2$$

$$I_1 = 0.6 - 0.6(1.14)$$

$$I_1 = -0.0811 \text{ A}$$

$$I_3 = I_1 + I_2$$

$$I_3 = -0.0811 + 1.14$$

$$I_3 = 1.06 \text{ A}$$

Finally, the node voltage at B is

$$V_B = 12I_3$$

$$V_B = 12(1.06)$$

$$V_B = 12.7 \text{ V}$$

**Sample Problem:**

Solve for  $I_1$ ,  $I_2$ ,  $I_3$ ,  $I_4$ , and  $I_5$  in the circuit below using nodal analysis.

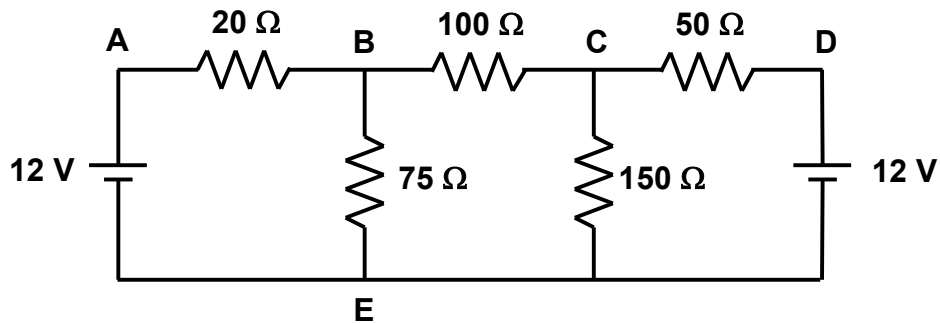

Figure 27 – Nodal analysis sample problem

At node B there is one current arriving and two currents leaving. The node equation at node B is

$$I_1 - I_2 - I_3 = 0$$

$$I_1 = I_2 + I_3$$

At node C there is one current arriving and two currents leaving. The node equation at node C is

$$I_3 - I_4 - I_5 = 0$$

$$I_3 = I_4 + I_5$$

Now, compute the voltage drops across each of the resistors

$$V_B - V_A = 20I_1$$

$$V_C - V_B = 100I_3$$

$$V_E - V_B = 75I_2$$

$$V_D - V_C = 50I_5$$

$$V_E - V_C = 150I_4$$

Substitute the known voltages into the equations

$$V_E = 0$$

$$V_A = 12 \text{ V}$$

$$V_D = 12 \text{ V}$$

$$V_B - V_A = 20I_1$$

$$V_B - 12 = 20I_1$$

$$V_C - V_B = 100I_3$$

$$V_E - V_B = 75I_2$$

$$0 - V_B = 75I_2$$

$$V_B = -75I_2$$

$$V_D - V_C = 50I_5$$

$$12 - V_C = 50I_5$$

$$V_E - V_C = 150I_4$$

$$0 - V_C = 150I_4$$

$$V_C = -150I_4$$

There are seven equations and seven unknowns.

$$I_1 = I_2 + I_3$$

$$I_3 = I_4 + I_5$$

$$V_B - 12 = 20I_1$$

$$V_C - V_B = 100I_3$$

$$V_B = -75I_2$$

$$12 - V_C = 50I_5$$

$$V_C = -150I_4$$

Let's eliminate the voltage variables and solve for the currents first.

$$V_B - 12 = 20I_1$$

$$V_B = 12 + 20I_1$$
  

$$V_C - V_B = 100I_3$$

$$V_C = V_B + 100I_3$$

$$V_C = 12 + 20I_1 + 100I_3$$
  

$$12 - V_C = 50I_5$$

$$V_C = 12 - 50I_5$$
  

$$V_B = -75I_2$$
  

$$V_C = -150I_4$$

Therefore,

$$V_B = 12 + 20I_1$$

$$-75I_2 = 12 + 20I_1$$

$$20I_1 + 75I_2 = -12$$

$$\begin{aligned}
 V_C &= 12 + 20I_1 + 100I_3 \\
 -150I_4 &= 12 + 20I_1 + 100I_3 \\
 20I_1 + 100I_3 + 150I_4 &= -12
 \end{aligned}$$

$$\begin{aligned}
 12 - V_C &= 50I_5 \\
 12 + 150I_4 &= 50I_5 \\
 150I_4 - 50I_5 &= -12
 \end{aligned}$$

Now, we are down to five equations and five unknowns.

$$\begin{aligned}
 I_1 &= I_2 + I_3 \\
 I_3 &= I_4 + I_5 \\
 20I_1 + 75I_2 &= -12 \\
 20I_1 + 100I_3 + 150I_4 &= -12 \\
 150I_4 - 50I_5 &= -12
 \end{aligned}$$

Now, let's solve for the individual currents.

$$\begin{aligned}
 150I_4 - 50I_5 &= -12 \\
 50I_5 &= 150I_4 + 12 \\
 I_5 &= 3I_4 + 0.24
 \end{aligned}$$

$$\begin{aligned}
 I_3 &= I_4 + I_5 \\
 I_3 &= I_4 + 3I_4 + 0.24 \\
 I_3 &= 4I_4 + 0.24 \\
 4I_4 &= I_3 - 0.24 \\
 I_4 &= 0.25I_3 - 0.06
 \end{aligned}$$

$$\begin{aligned}
 20I_1 + 100I_3 + 150I_4 &= -12 \\
 20I_1 + 100I_3 + 150(0.25I_3 - 0.06) &= -12 \\
 20I_1 + 100I_3 + 37.5I_3 - 9 &= -12 \\
 20I_1 + 137I_3 &= -3 \\
 137I_3 &= -20I_1 - 3 \\
 I_3 &= -0.146I_1 - 0.0219
 \end{aligned}$$

$$I_1 = I_2 + I_3$$

$$I_1 = I_2 - 0.146I_1 - 0.0219$$

$$1.15I_1 = I_2 - 0.0219$$

$$I_2 = 1.15I_1 + 0.0219$$

$$20I_1 + 75I_2 = -12$$

$$20I_1 + 75(1.15I_1 + 0.0219) = -12$$

$$20I_1 + 86.3I_1 + 1.64 = -12$$

$$106I_1 = -13.6$$

$$I_1 = -0.128 \text{ A (128 mA)}$$

$$I_2 = 1.15I_1 + 0.0219$$

$$I_2 = 1.15(-0.128) + 0.0219$$

$$I_2 = -0.125 \text{ A (-125 mA)}$$

$$I_3 = -0.146I_1 - 0.0219$$

$$I_3 = -0.146(-0.128) - 0.0219$$

$$I_3 = -0.00321 \text{ A (-3.21 mA)}$$

$$I_4 = 0.25I_3 - 0.06$$

$$I_4 = 0.25(-0.00321) - 0.06$$

$$I_4 = -0.0608 \text{ A (-60.8 mA)}$$

$$I_5 = 3I_4 + 0.2$$

$$I_5 = 3(-0.0608) + 0.24$$

$$I_5 = 0.0576 \text{ A (57.6 mA)}$$

Since  $I_1$ ,  $I_2$ ,  $I_3$ , and  $I_4$  are negative, then the direction of current flow is in the opposite direction chosen for each of these currents.

The node voltages are as follows:

$$V_A = 12 \text{ V}$$

$$V_B - 12 = 20I_1$$

$$V_B = 20I_1 + 12$$

$$V_B = 20(-0.128) + 12$$

$$V_B = 9.44 \text{ V}$$

$$V_C - V_B = 100I_3$$

$$V_C = V_B + 100I_3$$

$$V_C = 9.44 + 100(-0.00321)$$

$$V_C = 9.12 \text{ V}$$

$$V_D = 12 \text{ V}$$

$$V_E = 0 \text{ V}$$

To verify the results, let's put the results back into the original equations.

Results:

$$I_1 = -0.128 \text{ A}$$

$$I_2 = -0.125 \text{ A}$$

$$I_3 = -0.00321 \text{ A}$$

$$I_4 = -0.0608 \text{ A}$$

$$I_5 = 0.0576 \text{ A}$$

$$V_A = 12 \text{ V}$$

$$V_B = 9.44 \text{ V}$$

$$V_C = 9.12 \text{ V}$$

$$V_D = 12 \text{ V}$$

$$V_E = 0 \text{ V}$$

Equations:

$$I_1 - I_2 - I_3 = 0$$

$$I_3 - I_4 - I_5 = 0$$

$$V_B - V_A = 20I_1$$

$$V_C - V_B = 100I_3$$

$$V_E - V_B = 75I_2$$

$$V_D - V_C = 50I_5$$

$$V_E - V_C = 150I_4$$

$$I_1 - I_2 - I_3 = 0$$
$$-0.128 + 0.125 + 0.00321 = 0.000$$

$$I_3 - I_4 - I_5 = 0$$
$$-0.00321 + 0.0608 - 0.0576 = 0.000$$

$$V_B - V_A = 20I_1$$
$$V_B - V_A - 20I_1 = 0$$
$$9.44 - 12 - 20(-0.128) = 0.000$$

$$V_C - V_B = 100I_3$$
$$V_C - V_B - 100I_3 = 0$$
$$9.12 - 9.44 - 100(-0.00321) = 0.001$$

$$V_E - V_B = 75I_2$$
$$V_E - V_B - 75I_2 = 0$$
$$0 - 9.44 - 75(-0.125) = -0.065 \approx 0.0$$

$$V_D - V_C = 50I_5$$
$$V_D - V_C - 50I_5 = 0$$
$$12 - 9.12 - 50(0.0576) = 0.000$$

$$V_E - V_C = 150I_4$$
$$V_E - V_C - 150I_4 = 0$$
$$0 - 9.12 - 150(-0.0608) = 0.000$$



## Summary

Electric circuits range from very simple circuits containing one or more resistive components and a voltage source (such as a battery and a light bulb contained in a flashlight) to very elaborate, complicated circuits (such as the microprocessor circuit card inside your mobile phone).

Various fundamental laws and techniques related to DC circuit analysis were discussed in this course. The simple relationship of voltage, current, and resistance, known as Ohm's Law, is fundamental to electrical circuits. Voltage dividers and current dividers can be used to reduce the voltage in a portion of a circuit or the current through a branch in a circuit respectively. A series or parallel circuit can be reduced down to an equivalent circuit to simplify the analysis of a circuit. There are several different techniques to analyze a circuit. This course discussed mesh analysis which demonstrates Kirchhoff's Voltage Law and nodal analysis which demonstrates Kirchhoff's Current Law. Power dissipation in a resistor was also discussed and must be considered so that the resistor is not undersized in the circuit causing it to heat up and either damage or destroy the circuit in which it is contained.

## References

1. Cathey, Jimmie J., Ph.D. and Nasar, Syen A., Ph.D., *Schaum's Outline of Basic Electrical Engineering, 2<sup>nd</sup> Edition*, McGraw-Hill, New York, NY, 1997.
2. "DC Circuit Theory." Visited 5 May 2017  
<[http://www.electronics-tutorials.ws/dccircuits/dcp\\_1.html](http://www.electronics-tutorials.ws/dccircuits/dcp_1.html)>
3. "DOE Fundamentals Handbook, Electrical Science, Volume 1 of 4". Visited 1 June 2017 <<https://www.standards.doe.gov/standards-documents/1000/1011-bhdbk-1992-v1/@/@images/file>>
4. "Kirchhoff's Voltage Law." Visited 1 June 2017  
<<http://www.electronics-tutorials.ws/dccircuits/kirchhoffs-voltage-law.html>>
5. "Kirchhoff's Circuit Laws – Wikipedia, the Free Encyclopedia." Visited 1 June 2017  
<[https://en.wikipedia.org/wiki/Kirchhoff's\\_circuit\\_laws](https://en.wikipedia.org/wiki/Kirchhoff's_circuit_laws)>
6. "Kirchhoff's Current Law." Visited 1 June 2017  
<<http://www.electronics-tutorials.ws/dccircuits/kirchhoffs-current-law.html>>
7. Nahvi, Mahmood, Ph.D. and Edminister, Joseph A., *Schaum's Outline of theory and Problems of Electric Circuits, 4<sup>th</sup> Edition*, McGraw-Hill, New York, NY, 2003.
8. "Ohm – Wikipedia, the Free Encyclopedia." Visited 5 May 2017  
<<https://en.m.wikipedia.org/wiki/Ohm>>

## Final Exam – DC Circuits

1. The voltage drop across a 100 ohm resistor is  $V = 0.2\text{V}$ . The current through the resistor is \_\_\_\_\_.
  - a. 0.025 A
  - b. 0.003 A
  - c. 0.002 A
  - d. 0.004 A
2. The current through a 5 k $\Omega$  resistor is 0.1 mA. The voltage drop across the resistor is \_\_\_\_\_.
  - a. 4 V
  - b. 0.1 V
  - c. 3 V
  - d. 0.5 V
3. The voltage drop across a resistor is 0.5 V. The current through the resistor is 0.2 mA. The resistance of the resistor is \_\_\_\_\_.
  - a. 2500  $\Omega$
  - b. 250  $\Omega$
  - c. 1470  $\Omega$
  - d. 3000  $\Omega$
4. A 100  $\Omega$  resistor has a current of 40 mA running through it. The power dissipated through the resistor is \_\_\_\_\_.
  - a. 0.08 W
  - b. 0.16 W
  - c. 1 W
  - d. 0.32 W
5. The resistor in the problem above is used in a circuit with the same power dissipation. A minimal acceptable power rating for this resistor is \_\_\_\_\_.
  - a. 0.1 W
  - b. 0.08 W
  - c. 0.2 W
  - d. 0.05 W
6. Three resistors are connected in series having values of 150  $\Omega$ , 200  $\Omega$ , and 350  $\Omega$ . The total resistance is \_\_\_\_\_.
  - a. 700  $\Omega$
  - b. 350  $\Omega$
  - c. 200  $\Omega$
  - d. 70  $\Omega$

7. Two resistors are connected in parallel having values of  $4.7\text{ k}\Omega$  and  $10\text{ k}\Omega$ . The total resistance is \_\_\_\_\_.
- $1.47\text{ k}\Omega$
  - $5.17\text{ k}\Omega$
  - $4.70\text{ k}\Omega$
  - $3.20\text{ k}\Omega$

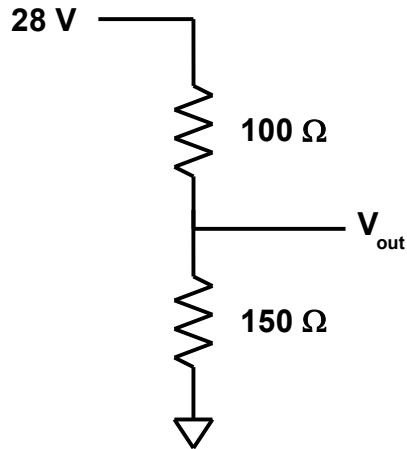

8. The output voltage of the voltage divider shown above is \_\_\_\_\_.
- $20.4\text{ V}$
  - $16.8\text{ V}$
  - $28.0\text{ V}$
  - $12.1\text{ V}$

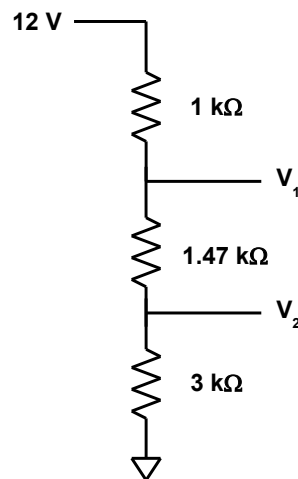

9. The output voltage,  $V_1$ , of the voltage divider shown above is \_\_\_\_\_.
- $9.81\text{ V}$
  - $8.87\text{ V}$
  - $10.3\text{ V}$

d. 7.46 V

10. The output voltage,  $V_2$ , of the voltage divider in the previous problem is \_\_\_\_\_.

- a. 5.13 V
- b. 7.24 V
- c. 5.73 V
- d. 6.58 V

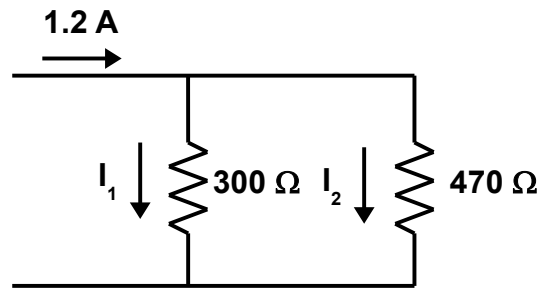

11. The branch current,  $I_1$ , in the current divider shown above is \_\_\_\_\_.

- a. 0.648 A
- b. 0.632 A
- c. 0.732 A
- d. 0.823 A

12. The branch current,  $I_2$ , in the current divider in the previous problem is \_\_\_\_\_.

- a. 0.672 A
- b. 0.468 A
- c. 0.734 A
- d. 0.832 A

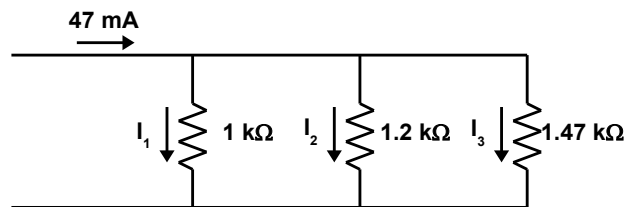

13. The branch current,  $I_1$ , in the current divider shown above is \_\_\_\_\_.

- a. 17.3 mA
- b. 16.8 mA
- c. 19.5 mA
- d. 18.7 mA

14. The branch current,  $I_2$ , in the current divider in the previous problem is \_\_\_\_\_.

- a. 15.6 mA

- b. 17.8 mA
- c. 12.2 mA
- d. 9.87 mA

15. The branch current,  $I_3$ , in the current divider in the previous problem is \_\_\_\_\_.

- a. 13.3 mA
- b. 15.2 mA
- c. 12.7 mA
- d. 21.3 mA

16. Voltage is added when flowing through a source, and subtracted when flowing through a resistor. Conventional current flow is defined as the same direction as \_\_\_\_\_ charges flow.

- a. negative
- b. no
- c. positive
- d. all

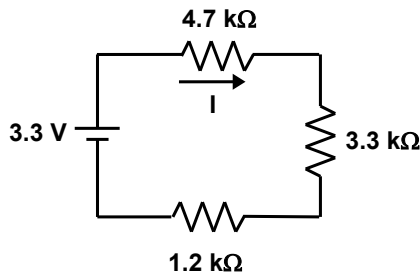

17. For the series circuit shown above, the current  $I$  in the circuit is \_\_\_\_\_.

- a. 642  $\mu\text{A}$
- b. 267  $\mu\text{A}$
- c. 481  $\mu\text{A}$
- d. 359  $\mu\text{A}$

18. The voltage drop in the 4.7 k $\Omega$  resistor in the series circuit in the previous problem is \_\_\_\_\_.

- a. 2.73 V
- b. 1.12 V
- c. 3.72 V
- d. 1.69 V

19. The voltage drop in the 3.3 k $\Omega$  resistor in the series circuit in the previous problem is \_\_\_\_\_.

- a. 1.18 V
- b. 2.68 V

- c. 0.432 V
- d. 3.12 V

20. The voltage drop in the 1.2 kΩ resistor in the series circuit in the previous problem is \_\_\_\_\_.

- a. 0.213 V
- b. 0.430 V
- c. 1.75 V
- d. 0.127 V

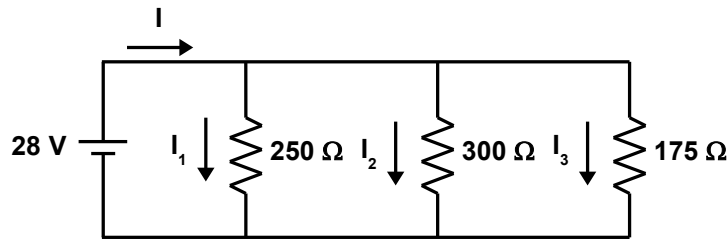

21. For the parallel circuit shown above, the current  $I_1$  is \_\_\_\_\_.

- a. 0.212 A
- b. 0.416 A
- c. 0.314 A
- d. 0.112 A

22. For the parallel circuit in the previous problem, the current  $I_2$  is \_\_\_\_\_.

- a. 0.127 A
- b. 0.213 A
- c. 0.0933 A
- d. 0.372 A

23. For the parallel circuit in the previous problem, the current  $I_3$  is \_\_\_\_\_.

- a. 0.160 A
- b. 0.153 A
- c. 0.172 A
- d. 0.281 A

24. For the parallel circuit in the previous problem, the total current  $I$  is \_\_\_\_\_.

- a. 0.214 A
- b. 0.576 A
- c. 0.365 A
- d. 0.127 A

25. For the parallel circuit in the previous problem, the voltage drop across the resistors is \_\_\_\_\_.

- a. 14 V
- b. 28 V
- c. 32 V
- d. 17 V

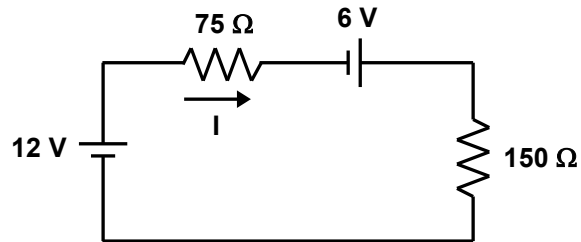

26. In the circuit shown above, the current  $I$  is \_\_\_\_\_.

- a. 0.12 A
- b. 0.05 A
- c. 0.17 A
- d. 0.08 A

27. In the circuit in the previous problem, the voltage drop in the  $75\ \Omega$  resistor is \_\_\_\_\_.

- a. 6 V
- b. 8 V
- c. 10 V
- d. 12 V

28. In the circuit in the previous problem, the voltage drop in the  $150\ \Omega$  resistor is \_\_\_\_\_.

- a. 6 V
- b. 8 V
- c. 12 V
- d. 10 V

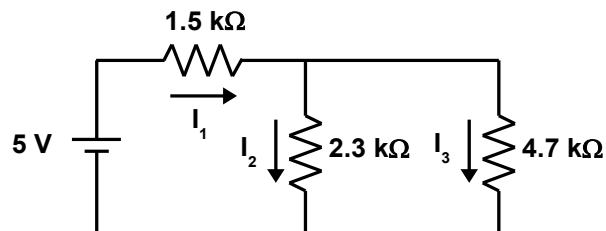

29. In the circuit shown above, the current  $I_1$  is \_\_\_\_\_.

- a. 2.73 mA
- b. 3.67 mA



- c. 0.157 mA
- d. 1.64 mA

30. In the circuit in the previous problem, the current  $I_2$  is \_\_\_\_\_.

- a. 2.35 mA
- b. 0.812 mA
- c. 3.72 mA
- d. 1.10 mA

31. In the circuit in the previous problem, the current  $I_3$  is \_\_\_\_\_.

- a. 0.214 mA
- b. 0.0126 mA
- c. 0.540 mA
- d. 0.725 mA

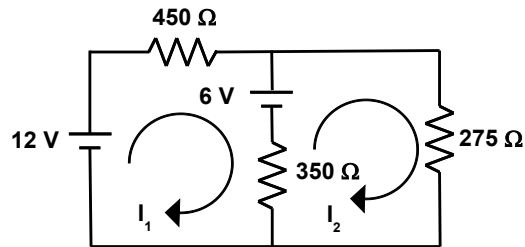

32. In the circuit shown above, the mesh current  $I_1$  is \_\_\_\_\_.

- a. 0.0155 A
- b. 0.0286 A
- c. 0.127 A
- d. 0.00861 A

33. In the circuit in the previous problem, the mesh current  $I_2$  is \_\_\_\_\_.

- a. 0.0297 A
- b. 0.372 A
- c. 0.218 A
- d. 0.0183 A

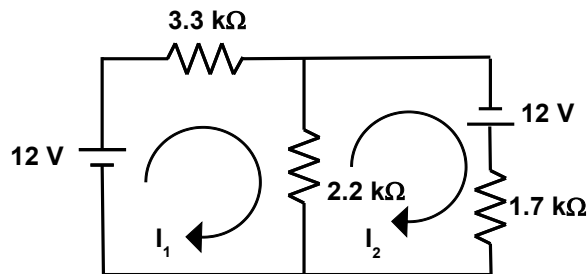

34. In the circuit shown above, the mesh current  $I_1$  is \_\_\_\_\_.

- a. 4.41 mA
  - b. 2.76 mA
  - c. 8.23 mA
  - d. 5.91 mA
35. In the circuit in the previous problem, the mesh current  $I_2$  is \_\_\_\_\_.
- a. 8.71 mA
  - b. 1.23 mA
  - c. 5.56 mA
  - d. 2.42 mA
36. A series circuit has \_\_\_\_\_ path(s) for current flow.
- e. two
  - f. one
  - g. multiple
  - h. no
37. A parallel circuit has \_\_\_\_\_ path(s) for current flow.
- a. only one
  - b. only two
  - c. multiple
  - d. no
38. It is ok to dissipate 10 watts of power through a resistor that is rated for 2 watts.
- a. False
  - b. True
39. Power dissipation in a resistor \_\_\_\_\_ as resistance increases.
- a. increases
  - b. decreases
  - c. stays the same
  - d. none of the above
40. Voltage equals \_\_\_\_\_ times resistance.
- a. voltage
  - b. resistance
  - c. power
  - d. current
41. The equation in the above problem is known as \_\_\_\_\_ Law.
- a. Tesla's
  - b. Maxwell's
  - c. Ohm's

- d. Faraday's
42. An ohm is defined as the electrical resistance between two points of a conductor when a constant potential difference of \_\_\_\_\_, applied to these points, produces in the conductor a current of 1 amp.
- a. 0 volts
  - b. 1 volt
  - c. 1000 volts
  - d. 2 volts
43. In order to determine the current through a resistor, you must know the resistance as well as the \_\_\_\_\_ across the resistor.
- a. voltage
  - b. capacitance
  - c. inductance
  - d. magnetic field strength
44. Power is measured in \_\_\_\_\_.
- a. Watts
  - b. Ohms
  - c. Volts
  - d. Joules
45. In order to find the total resistance in a series circuit, you must \_\_\_\_\_ each resistor value.
- a. subtract
  - b. multiply
  - c. add
  - d. divide